



Service instructions

**CRE 1, CRE 3 and CRE 5
Model A**

**50/60 Hz
1/3~**

1.	Type identification	2
1.1	Nameplate	2
1.2	Type key	3
2.	Tightening torques and lubricants	4
3.	Service tools	5
3.1	Special tools	5
3.2	Standard tools	6
3.3	Torque tools	6
4.	Dismantling and assembly	7
4.1	General	7
4.2	Replacement of motor	8
4.3	Replacement of shaft seal	9
4.4	Dismantling and assembly of pump main parts	10
4.5	Dismantling and assembly of chamber stack	11
4.6	Dismantling and assembly of base and pump head	12
4.7	Checking and replacing parts	13
5.	Order of assembly for chambers and impellers	14
5.1	CRE 1 and CRE 3	14
5.2	CRE 5	15

1. Type identification

This section shows the type key, the nameplate and the codes that can appear in the variant code.

Note: As codes can be combined, a code position may contain more than one letter.

1.1 Nameplate

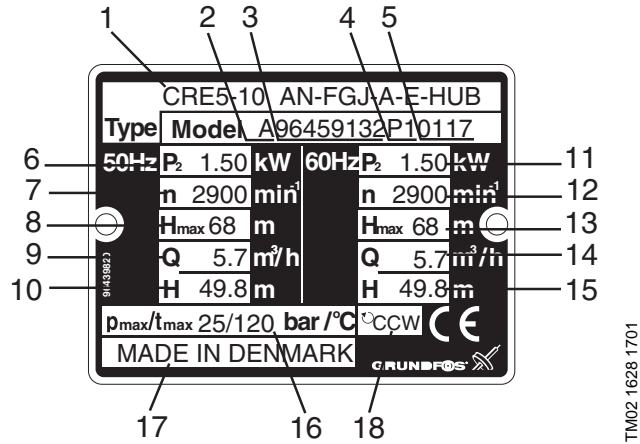

TM02 1628 1701

Pos.	Description	Pos.	Description
1	Type designation. See 1.2 Type key	10	Head at rated flow rate, 50 Hz
2	Model	11	P ₂ , 60 Hz
3	Product number	12	Speed, 60 Hz
4	Place of production	13	Head against closed valve, 60 Hz
5	Production year and week	14	Rated flow rate, 60 Hz
6	P ₂ , 50 Hz	15	Head at rated flow rate, 60 Hz
7	Speed, 50 Hz	16	Maximum pressure and temperature
8	Head against closed valve, 50 Hz	17	Country of production
9	Rated flow rate, 50 Hz	18	Direction of rotation (CCW = counterclockwise)

1.2 Type key

Example	CRE	5 -	10	X-	X-	X-	X-	XXXX
Type range								
Rated flow rate in m ³ /h								
Number of stages								
Code for pump version A = Basic version G = Pump for booster system N = Pump with pressure sensor U = NEMA version								
Code for pipe connection A = Oval flange FGJ = DIN, ANSI and JIS flange								
Code for pump materials A = Pump head and base: Cast iron Other wetted parts: Stainless steel DIN W.-Nr. 1.4301								
Code for rubber parts E = EPDM V = FKM								
Code for shaft seal HUBE/V = Balanced cartridge seal; rotating face: tungsten carbide; stationary seat: resin-impregnated carbon; O-rings, see code for rubber parts.								
HUUE/V = Balanced cartridge seal; rotating face: tungsten carbide; stationary seat: tungsten carbide; O-rings, see code for rubber parts.								

2. Tightening torques and lubricants

Pos.	Description	Number	Dim.	Torque [Nm]	Lubricant
7a	Screw	4	M4	2	
9	Hexagon socket head screw	4	M6	13	THREAD-EZE
			M8	31	
			M10	62	
18	Air vent screw (spindle)	1	½" (M8)	35 (3)	
23	Plug	1	½"	35	Soapy water
25	Drain plug with bypass valve (spindle)	1	½" (M10)	35 (5)	
26	Staybolt	4	M12		THREAD-EZE
			M6	10	
28	Hexagon head screw	4	M8	12	THREAD-EZE
			M12	40	
			M10	23	
35	Hexagon head screw	4	M10	23	THREAD-EZE
36	Nut	4	M12	50	THREAD-EZE
37	O-ring	2	ø137.5 x 3.3		Rocol 22
47a	Bearing ring	See 5. Order of assembly for chambers and impellers			Rocol 22
67	Lock nut	1	M8	18	Gardolube L 6034
105	Shaft seal	1	M28	35	
113	Set screw	3	M5	2.5	

THREAD-EZE, part no. SV9997 (0.5 l).

Gardolube L 6034, part no. SV9995 (1 l).

Rocol 22, part no. RM2924 (1 kg).

3. Service tools

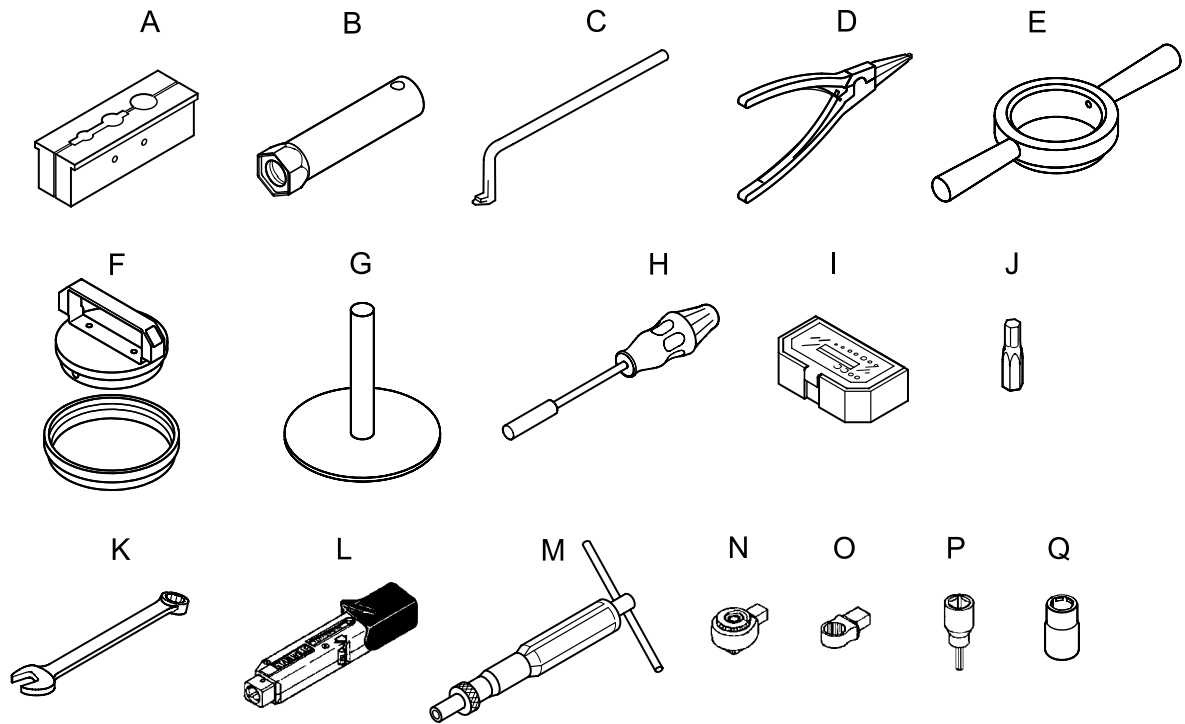

TM02 0846 0401

3.1 Special tools

Pos.	Description	For pos.	Suppl. information	Part no.
A	Shaft holder for assembly			SV0040
B	Tubular box spanner for shaft seal	105		SV2007
C	Puller	65		SV0239
D	Circlip pliers (not used for CR)			SV2014
E	Tool for outer sleeve	55		V7170478
F	Tool for corrugated spring	60		V7170227
G	Tool for O-ring	37		V7170230

3.2 Standard tools

Pos.	Description	Bit no.	For pos.	Suppl. information	Part no.
H	Bit holder		I-J	1/4"	SV2011
		PZ2	7a	1/4"	
I	Bits kit	5	9-H	M6 - 5 mm	SV2010
		6		M8 - 6 mm	
		8		M10 - 8 mm	
J	Hexagon bit		113-H-M	M5 - 2.5 mm	SV2012
			28	M6 - 10 mm	SV0083
			28-67	M8 - 13 mm	SV0055
K	Ring/open-end spanner		35	M10 - 17 mm	SV0056
			28-36	M12 - 19 mm	SV0054
			18-23-25	M16 - 24 mm	SV0122

3.3 Torque tools

Pos.	Description	For pos.	Suppl. information	Part no.		
L	Torque wrench	N-O	4-20 Nm	9 x 12	SV0292	
			20-100 Nm	9 x 12	SV0269	
			40-200 Nm	14 x 18	SV0400	
M	Torque screwdriver	J	1-6 Nm	1/4"	SV0438	
N	Ratchet insert tool	L-O-P	9 x 12 -> 1/2"		SV0295	
O	Ring insert tool		28-L	M6 - 10 mm	9 x 12	SV0310
			28-L	M8 - 13 mm	9 x 12	SV0294
			28-L	M10 - 17 mm	9 x 12	SV0270
			36-L	M12 - 19 mm	9 x 12	SV0271
			18-23-25-L	M16 - 24 mm	9 x 12	SV0524
P	Hexagon socket driver	9-N	M6 - 5 mm	1/2" x 1/2"	SV0296	
			M8 - 6 mm	1/2" x 1/2"	SV0297	
			M10 - 8 mm	1/2" x 1/2"	SV0298	
Q	Socket spanner, purpose-ground	67-L	M8 - 13 mm	9 x 12	SV2013	

4. Dismantling and assembly

4.1 General

If it is necessary to dismantle the pump, either because it is choked or damaged, please follow the instructions in the following sections.

Position numbers of parts (digits) refer to exploded views, sectional drawings and parts lists; position numbers of tools (letters) refer to [3. Service tools](#).

4.1.1 Before dismantling the pump

- Disconnect the electricity supply to the motor.
- Close the isolating valves, if fitted, to avoid draining the system.
- *Remove the electric cable in accordance with local regulations.*
- Note the centre of gravity of the pump to prevent it from overturning. This is especially important in the case of long pumps.

4.1.2 Before assembly

- Clean and check all parts.
- Order the necessary service kits.
- Replace defective parts by new parts.
- Gaskets and O-rings should always be replaced when the pump is overhauled.

4.1.3 During assembly

- Lubricate and tighten the screws and nuts to correct torque as stated in [2. Tightening torques and lubricants](#).

4.1.4 After assembly

- The pump should be tested according to test specification 96446769.

4.2 Replacement of motor

4.2.1 Dismantling

1. Disconnect the pressure sensor, if fitted, from the terminal box of the motor. See fig. 1.

MGE 71, MGE 80

MGE 90, MGE 100, MGE 112, MGE 132

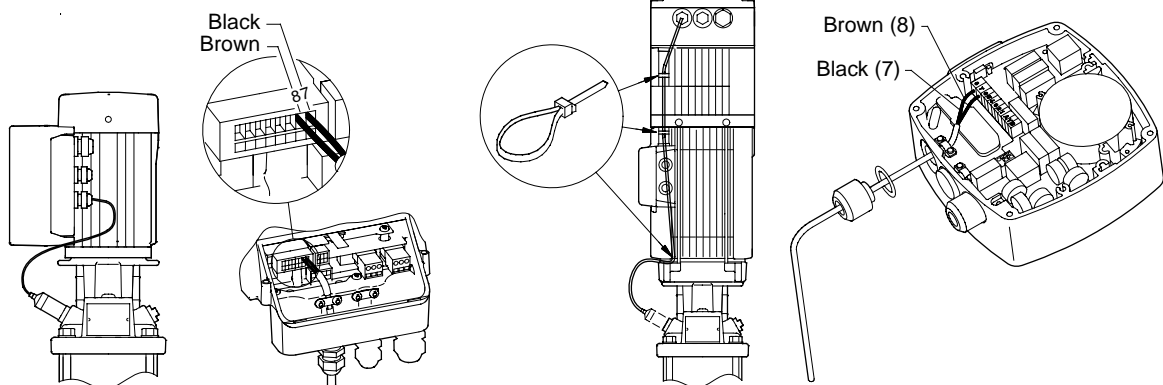

Fig. 1

2. Slacken and remove the screws (pos. 7a) together with the coupling guard (pos. 7)
3. Slacken and remove the screws (pos. 9) together with the coupling halves (pos. 10a) and the shaft pin (pos. 10).
4. Slacken and remove the screws (pos. 28).
5. Lift the motor off the pump head (pos. 2).

4.2.2 Assembly

1. Fit the motor to the pump head.
2. Fit the screws (pos. 28) and tighten diagonally to the correct torque.
3. Fit the shaft pin (pos. 10) into the shaft pin hole.
4. Fit the coupling halves (pos. 10a) on the shaft and fit the screws (pos. 9). Tighten the screws and leave loose. *Check that the gaps either side of the coupling halves are equal.*
5. Tighten the screws (pos. 9) diagonally to the correct torque. *Check that the gaps either side of the coupling halves are equal. See fig. 2.*

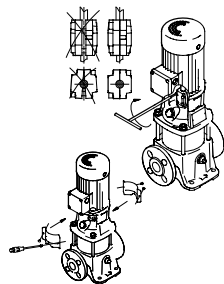

Fig. 2

6. Fit the coupling guard (pos. 7) and the screws (pos. 7a).
7. Connect the pressure sensor, if any, to the terminal box of the motor. See fig. 1.

TM02 1629 1701

4.3 Replacement of shaft seal

4.3.1 Dismantling

1. Remove the motor and the coupling. See [4.2.1 Dismantling](#).
2. Slacken the three screws (pos. 113) by approx. a $\frac{1}{4}$ of a turn so that the shaft seal is just free of the shaft.
3. Slacken the shaft seal (pos. 105) using the box spanner (pos. B) until the thread is completely free of the pump head.
4. Pull the shaft seal off the shaft.

4.3.2 Assembly

1. If necessary, clean and smooth the shaft end using the holder with emery cloth supplied with the shaft seal kit.
2. Moisten the shaft end with soapy water.
3. Place the shaft seal in the box spanner (pos. B) and press it down on the shaft.
4. Screw the shaft seal into the pump head and tighten it to the correct torque.
5. Fit the shaft pin (pos. 10) into the shaft pin hole and fit the coupling halves (pos. 10a) on the shaft. Fit the screws (pos. 9), tighten and leave loose.
Check that the gaps either side of the coupling halves are equal. See fig. 2.
6. Fit the motor to the pump head.
7. Fit the screws (pos. 28) and tighten diagonally to the correct torque.
8. Insert a suitable screwdriver between the bottom of the coupling and the shaft seal, and raise the shaft/the coupling against stop. See fig. 3.

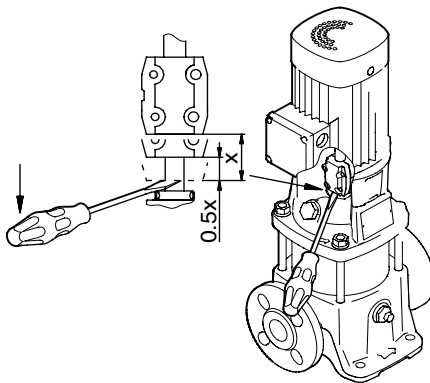

TM02 0462 4600

Fig. 3

9. Lower the shaft/the coupling to half that height. See fig. 3.
10. Hold the shaft/the coupling in this position and tighten the four screws in the coupling (pos. 9) to the correct torque.
Check that the gaps either side of the coupling halves are equal. See fig. 2.
11. Tighten the three screws (pos. 113) to the correct torque.
12. Fit the coupling guard (pos. 7) and the screws (pos. 7a).
13. Connect the pressure sensor, if any, to the terminal box of the motor. See fig. 1.

4.4 Dismantling and assembly of pump main parts

4.4.1 Dismantling

1. Remove the shaft seal. See [4.3.1 Dismantling](#).
2. Remove the pressure sensor, if fitted, from the pump head (pos. 2).
3. Slacken and remove the screws (pos. 36) together with the washers (pos. 66a).
4. Loosen the pump head (pos. 2) with a light blow on the edge and lift it free of the staybolts (pos. 26). The top guide vanes/discharge part (pos. 50a) may stick to the pump head.
5. Loosen the top guide vanes/discharge part (pos. 50a) with a light blow of a rubber mallet if it was not removed with the pump head.
6. Remove the outer sleeve (pos. 55).
7. Lift the chamber stack off the base. If the bottom chamber (pos. 5a) is removed with the chamber stack, loosen it from the chamber stack; otherwise loosen it from the base (pos. 6).

4.4.2 Assembly

1. Fit the chamber stack in the base. The smooth shaft end must be upwards.
2. Fit the outer sleeve (pos. 55) in the base and press it home in the base using the tool (pos. E).
The O-ring (pos. 37) must be lubricated. See 2. Tightening torques and lubricants.
3. Press the top guide vanes/discharge part (pos. 50) into the recess of the top chamber.
4. Fit the pump head on the pump with the air vent screw (pos. 18) in the direction required.
The O-ring (pos. 37) must be lubricated. See 2. Tightening torques and lubricants.
5. Lubricate the threads of the staybolts. See [2. Tightening torques and lubricants](#).
6. Fit the washers (pos. 66a) and the nuts (pos. 36).
7. Tighten the nuts (pos. 36) diagonally to the correct torque.
8. Fit the pressure sensor, if any, to the pump head (pos. 2).

4.5 Dismantling and assembly of chamber stack

4.5.1 Dismantling

1. Remove the chamber stack. See [4.4.1 Dismantling](#).
2. Place the shaft holder (pos. A) in a vice, but do not tighten the vice.
3. Fit the shaft pin (pos. 10) into the shaft pin hole and place the chamber stack in the shaft holder (pos. A). See fig. 4. Tighten the vice.

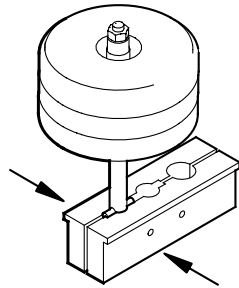

TM02 1056 0501

Fig. 4

4. Remove the nut (pos. 67), the washer (pos. 66) and the clamp (pos. 64c).
5. Remove the chamber stack components: impeller, chamber, bearing ring and spacing pipe. See [5. Order of assembly for chambers and impellers](#).

4.5.2 Assembly

1. Place the shaft holder (pos. A) in a vice, but do not tighten the vice.
2. Fit the shaft pin (pos. 10) into the shaft pin hole and place the shaft in the shaft holder (pos. A). Tighten the vice.
3. Fit the components on the shaft: impeller, chamber, spacing pipe and bearing ring. See [5. Order of assembly for chambers and impellers](#).
4. Fit the clamp (pos. 64c), the washer (pos. 66) and the nut (pos. 67). Tighten to the correct torque.
The washer (pos. 66) consists of two washers glued together. If they have been separated, make sure that they are fitted correctly. See fig. 5.

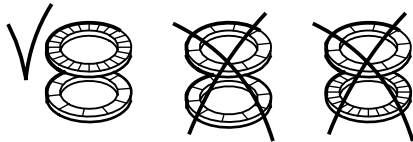

TM02 1057 0501

Fig. 5

5. Slacken the vice and remove the chamber stack and the shaft pin (pos. 10).
6. Place the bottom chamber (pos. 5a) on the chamber stack.

4.6 Dismantling and assembly of base and pump head

4.6.1 Dismantling of base

1. Remove the staybolts (pos. 26) from the base (pos. 6).
2. Remove flange connection, if any:
Oval flange: Remove the screws (pos. 35), the flange (pos. 12) and the gasket (pos. 39).
3. Remove the drain plug (pos. 25) and the O-ring (pos. 38).
4. Remove the O-ring (pos. 37).

4.6.2 Dismantling of pump head

1. Remove the air vent screw (pos. 18), the plug (pos. 23) and the O-ring (pos. 100).
2. Remove the O-ring (pos. 37).
3. Remove the corrugated spring (pos. 60).

4.6.3 Assembly of base

1. Fit the O-ring (pos. 37) using the tool (pos. G). See fig. 6.

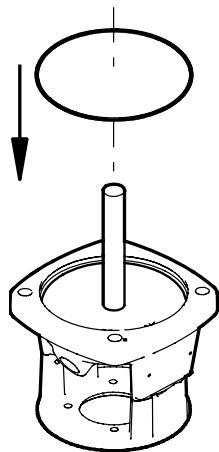

TM02 1055 0501

Fig. 6

2. Fit the flange connection, if any:
Oval flange: Fit the gasket (pos. 39), the flange (pos. 12) and the screws (pos. 35).
3. Lubricate the threads of the staybolts, see 2. [Tightening torques and lubricants](#), and fit the staybolts in the base (pos. 6). Tighten the staybolts using your fingers.
4. Fit the O-ring (pos. 38) on the drain plug (pos. 25) and fit the plug into the base.

4.6.4 Assembly of pump head

1. Fit the O-rings (pos. 100) on the air vent screw (pos. 18) and the plug (pos. 23). Fit the screw and the plug into the pump head.
2. Fit the corrugated spring (pos. 60) in the pump head using the tool (pos. F). See fig. 7.

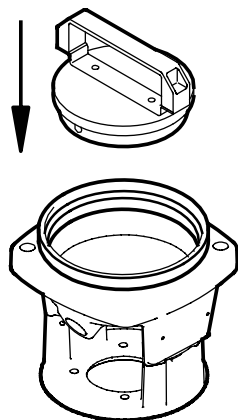

TM02 0462 4600

Fig. 7

3. Fit the O-ring (pos. 37) using the tool (pos. G). See fig. 6.

4.7 Checking and replacing parts

Check	Replace
Impeller	Neck ring/retainer for neck ring
<ul style="list-style-type: none"> Check whether it is necessary to replace the impeller due to friction between the neck ring and the impeller skirt. <p>If wear has caused a noticeable (use a finger nail) groove in the impeller skirt, the impeller should be replaced.</p> <p>Neck rings and retainers for neck rings should always be replaced when the chamber stack is dismantled.</p>	<ol style="list-style-type: none"> Prise the retainer for neck ring (pos. 65) up and free of the chamber using the puller (pos. C). Remove the neck ring (pos. 45). Fit a new neck ring into the chamber. See fig. 8. Press a new retainer for neck ring down on the neck ring and into the chamber. <p><i>It must be possible to move the neck ring freely (sideways) between the retainer and the chamber.</i></p>
Bearing rings	
<ul style="list-style-type: none"> Check whether there is a visible and noticeable (use a finger nail) edge on the rotating bearing ring. 	<ul style="list-style-type: none"> Replace both bearing rings (pos. 47a) and the chamber with bearing ring (pos. 4a).

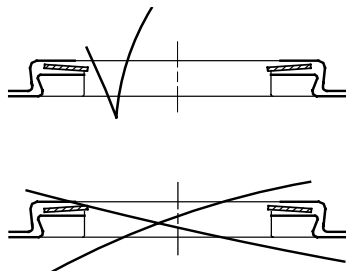

Fig. 8

TM02 1182 0601

5. Order of assembly for chambers and impellers

1. Determine the pump type (CRE 1, CRE 3 or CRE 5) and the stage variant. Find the pump in the relevant stage survey table.
2. Find the components of each stage in the symbol survey.

5.1 CRE 1 and CRE 3

Stage survey

	2	3	4	5	6	7	8	9	10	11	12	13	15	17	19	21	23	25	27	29	30	31	33	36		
	⊗	⊗	⊗	⊗	⊗	⊗	⊗	⊗	⊗	⊗	⊗	⊗	⊗	⊗	⊗	⊗	⊗	⊗	⊗	⊗	⊗	⊗	⊗	⊗	1	
	○	★	★	★	★	★	★	★	★	★	★	★	★	★	★	★	★	★	★	★	★	★	★	★	★	2
		★	★	★	★	★	★	★	★	★	★	★	★	★	★	★	★	★	★	★	★	★	★	★	★	3
			★	★	★	★	★	★	★	★	★	★	★	★	★	★	★	★	★	★	★	★	★	★	★	4
				★	★	★	★	★	★	★	★	★	★	★	★	★	★	★	★	★	★	★	★	★	★	5
					★	★	★	★	★	★	★	★	★	★	★	★	★	★	★	★	★	★	★	★	★	6
						★	★	★	★	★	★	★	★	★	★	★	★	★	★	★	★	★	★	★	★	7
							★	★	★	★	★	★	★	★	★	★	★	★	★	★	★	★	★	★	★	8
								★	★	★	★	★	★	★	★	★	★	★	★	★	★	★	★	★	★	9
									★	★	★	★	★	★	★	★	★	★	★	★	★	★	★	★	★	10
										★	★	★	★	★	★	★	★	★	★	★	★	★	★	★	★	11
											★	★	★	★	★	★	★	★	★	★	★	★	★	★	★	12
												★	★	★	★	★	★	★	★	★	★	★	★	★	★	13
													★	★	★	★	★	★	★	★	★	★	★	★	★	14
														★	★	★	★	★	★	★	★	★	★	★	★	15
															★	★	★	★	★	★	★	★	★	★	★	16
																★	★	★	★	★	★	★	★	★	★	17
																	★	★	★	★	★	★	★	★	★	18
																		★	★	★	★	★	★	★	★	19
																			★	★	★	★	★	★	★	20
																				★	★	★	★	★	★	21
																					★	★	★	★	★	22
																						★	★	★	★	23
																							★	★	★	24
																								★	★	25
																									★	26
																										27
																										28
																										29
																										30
																										31
																										32
																										33
																										34
																										35
																										36

Symbol survey

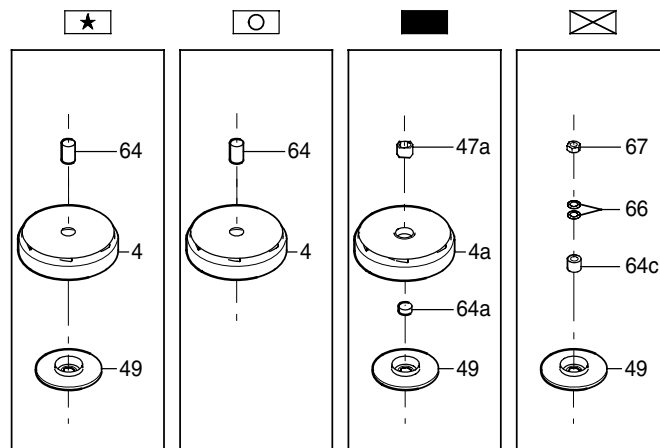

TN02 0445 1701

5.2 CRE 5

Stage survey

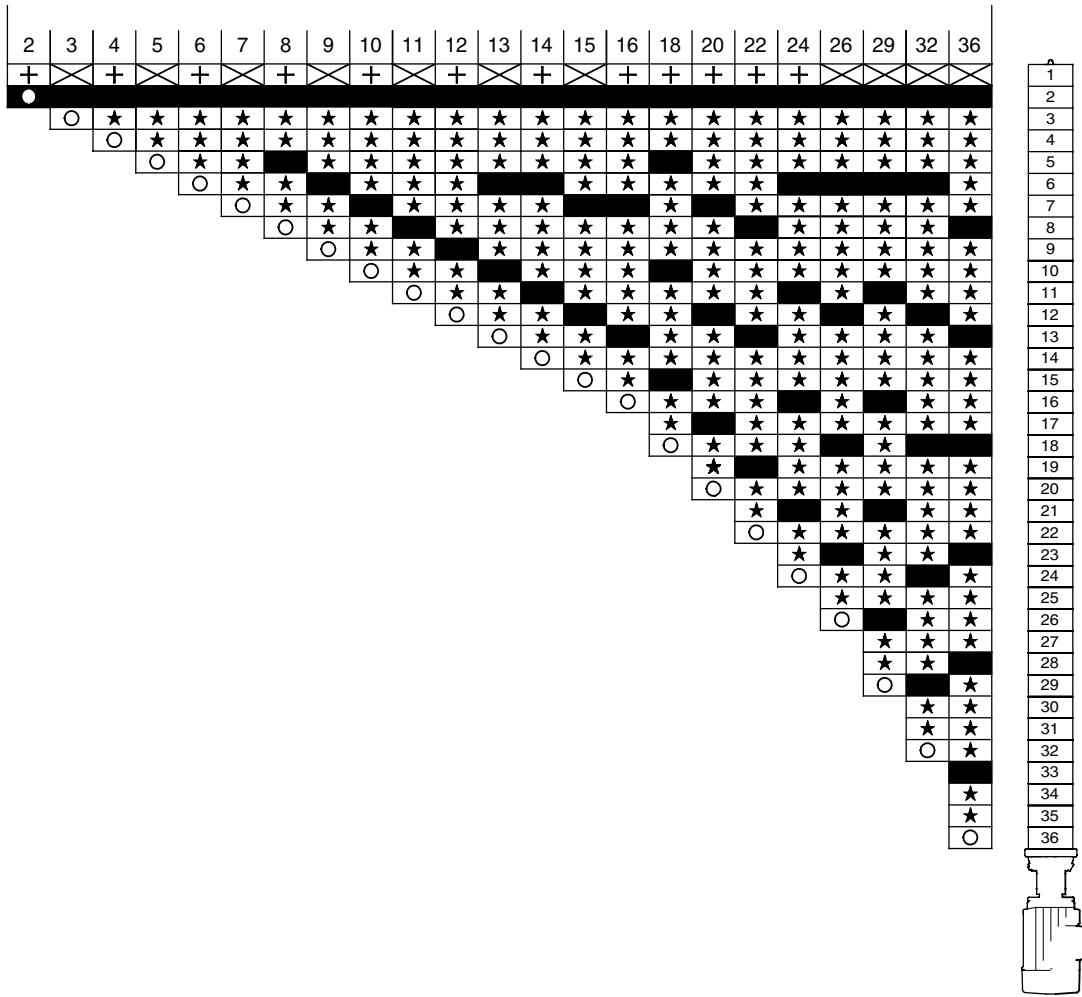

Symbol survey

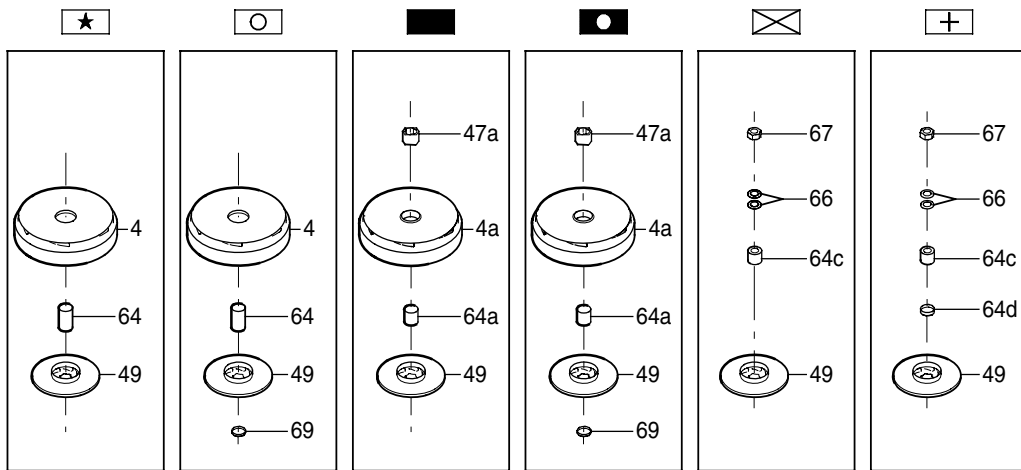

TM02 0444 4600